

SSM1A130BD

Harmony, Solid state modular relay, 30 A, DIN rail mount, zero voltage switching, input 4...32 V DC, output 24...280 V AC

Product availability : Non-Stock - Not normally stocked in distribution facility



Main

Range of product	Harmony Solid State Relays
Product or component type	Solid state relay up to 30 A
Device short name	SSM1
Number of phases	1 phase
Output switching mode	Zero voltage switching

Complementary

Mounting support	Symmetrical DIN rail
Line Rated Current	30 A
Output voltage	24...280 V AC
[Uc] control circuit voltage	4...32 V DC
Tightening torque	0.6...0.7 N.m for input 1.36...1.7 N.m for output
Connections - terminals	Screw terminals 1 x 0.2...1 x 5.3 mm ² , AWG 24...AWG 10) input Screw terminals 1 x 0.2...1 x 5.3 mm ² , AWG 24...AWG 10) output
Maximum capacitance	8 pF for input/output
Insulation resistance	1000 MOhm at 500 V DC
Local signalling	for input status LED (green)
Switching voltage	4 V DC turn-on 1 V DC turn-off
Input current	8...12 mA
Solid state output type	Zero voltage switching SCR output
Load current	0.15...30 A
Transient overvoltage	600 V

* Price is "List Price" and may be subject to a trade discount – check with your local distributor or retailer for actual price.

Surge current	1200 A 16.6 ms
Maximum voltage drop	<1.6 V on-state
Maximum I ² t for fusing	6000 A ² .s for 8.3 ms
Maximum leakage current	10 mA off-state
DV/Dt	500 V/μs off-state at maximum voltage
Response time	0.5 cycle (turn-on) 0.5 cycle (turn-off)
Overvoltage category	III
Net Weight	0.62 lb(US) (0.28 kg)

Environment

Dielectric strength	4 kV AC for input/output 4 kV AC for input or output to case
Pollution degree	2
Standards	CSA C22.2 No 14 UL 508 IEC 60950-1
Product certifications	UL EAC CSA
Marking	CE EAC UL CSA
IP degree of protection	IP20
Ambient air temperature for operation	-40...176 °F (-40...80 °C)
Ambient air temperature for storage	-40...257 °F (-40...125 °C)

Ordering and shipping details

Category	22375 - INTERFACE MODULE(ABA,R,S)
Discount Schedule	CP2
GTIN	00785901271796
Nbr. of units in pkg.	1
Package weight(Lbs)	1 lb(US) (0.45 kg)
Returnability	Yes
Country of origin	MX

Packing Units

Package 1 Height	0.310 dm
Package 1 width	1.100 dm
Package 1 Length	1.100 dm

Offer Sustainability

Sustainable offer status	Green Premium product
California proposition 65	WARNING: This product can expose you to chemicals including: Lead and lead compounds, which is known to the State of California to cause cancer and birth defects or other reproductive harm. For more information go to www.P65Warnings.ca.gov
REACH Regulation	REACH Declaration
EU RoHS Directive	Pro-active compliance (Product out of EU RoHS legal scope) EU RoHS Declaration
Mercury free	Yes
RoHS exemption information	Yes
China RoHS Regulation	China RoHS declaration
Environmental Disclosure	Product Environmental Profile
Circularity Profile	End of Life Information

Dimensions

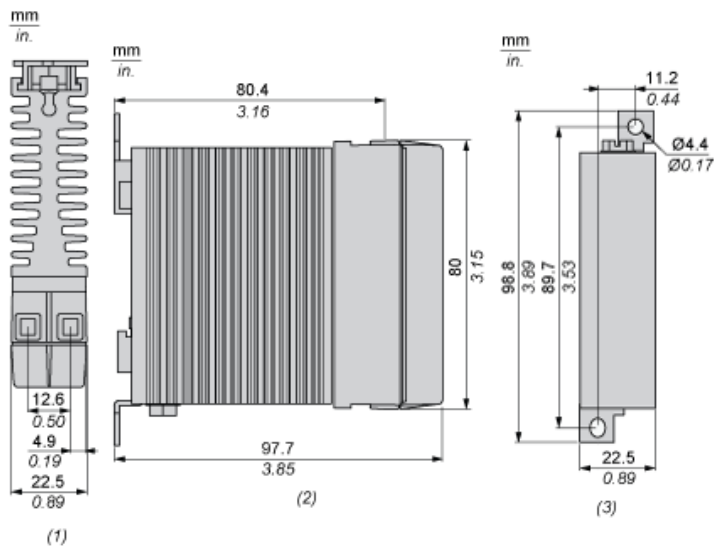

- (1) Top view
- (2) Side view
- (3) Front view

Derating Curves

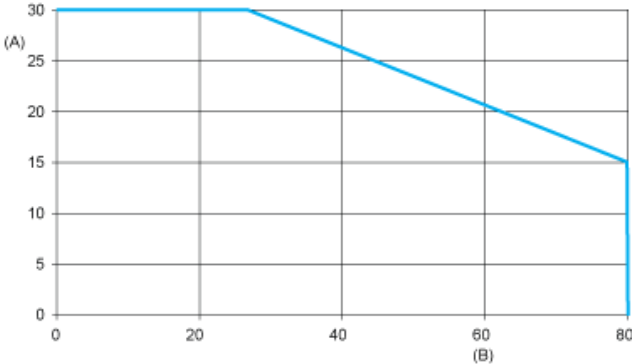

A : Load Current (Amperes)
B : Ambient Temperature (°C)